



SHERMAC

Engineered Equipment
Transitions



ROADSERVE 4000 WATER CART

EXPERIENCE THAT'S DRIVING A NEW ERA IN VEHICLE ENGINEERING

At Shermac, we've been manufacturing engineered-for-purpose service vehicles and water cartage vehicles for Australia's mining, civil and construction sectors since 2002.

We've earned a deserved reputation for excellence among heavy industry and government organisations alike. But it's not purely the quality, reliability and functionality of our high-performance vehicles that have driven our ongoing growth and the evolution of our range.

Nor is it simply our design, engineering and manufacturing expertise.

It's more fundamental than that.

Listening, evolving, solving.
The most crucial skill in our proven engineering process is the ability to listen and build relationships.

This is what underpins our expertise in designing and delivering cost-effective, quality-assured solutions that drive performance capacity and add tangible operational and strategic value.

It's the foundation of our global sourcing and procurement network, which gives our clients access to the largest range of high-quality products at the lowest fleet and bulk-purchasing prices.

And it's why we now have three distinct divisions, each dedicated to meeting the unique needs of different industries across Australia.

MORE TAILORED MORE COST-EFFECTIVE

Some vehicle suppliers simply stock and sell standard vehicles. Not us. At Shermac, we create tailored solutions and engineered-for-purpose vehicles - it's the only way to provide the best value for money and performance in the field.

That's why we operate as three distinct divisions - Mining, Civil and Commercial - allowing us to meet the unique needs of different industries across the globe.

And that's why, before we start talking models and specs, we'll first consult with you to establish your strategic, operational and budgetary requirements. Only then will we be able to recommend and build the ideal solution - a water cartage vehicle or fleet that saves you time and money.



Contact us to discuss
YOUR unique requirements!

1300 799 943
sales@shermac.com.au
www.shermac.com.au

PERFORMANCE, RELIABILITY, FLEXIBILITY

Our water trucks are engineered-for-purpose and extensively tested to ensure optimum weight distribution and performance on any chassis, no matter how tough the environment or challenge.

From 6,000 litre water carts through to 29,000 litre semi tankers, and then up to the large off-road gear, all our water trucks are engineered to your unique technical specs, giving you the freedom to custom-configure your vehicle to suit your practical requirements and augment your fleet.

ONE-STOP-SHOP

Shermac's diverse in-house capabilities include design and engineering, procurement, complete fabrication capabilities including assembly, testing, hydraulic engineering, auto electric, blast/paint and commissioning, and extends to transport, delivery, operator training, after-sales support and parts.

This end-to-end capability means that Shermac can supply the complete package, and is a one-stop-shop throughout the process, eliminating the external 'middle man'. This full accountability for every aspect of the project provides a much more predictable cost base, with complete control over quality and improved management of project timelines.



USABILITY

Our water carts are ergonomically designed to be easy to use and maintain. All pipework is hot dip galvanised and mounted externally to the water tank, eliminating pipe corrosion and making way for easy service access.



FLEXIBILITY

Each water cart is engineered and configured to suit your requirements and chassis type, and is able to work effectively in the conditions and environment where it is expected to operate.



SAFETY

Operator safety is always first at Shermac. Our off-road water carts are built with a low centre of gravity, increasing stability and safety. All our trucks are built to Australian Standards and are packed with safety features to help safeguard the operator.



RELIABILITY

Every element in every truck has been engineered to perform with heavy-duty use in the harshest conditions. For example, Shermac's water tanks are designed with unique curved sides to give extra integrity and improved aesthetic appearance. This greatly increases stability and safety.



Contact us to discuss
YOUR unique requirements!

1300 799 943
sales@shermac.com.au
www.shermac.com.au

WATER APPLICATION SYSTEMS

Our water application systems include left and right batter sprays, horizontal central fan sprays, hydraulic or electric controlled water cannons (with optional foam injection system), customised dribble bar options, optional front sprays and scope for any additional custom spray kits you may require.



WATER PUMP

We fit quality Australian-made hydraulic powered centrifugal pumps to all off-road water carts to ensure optimum performance. Pumps are mounted in an easily accessible location if servicing is required.

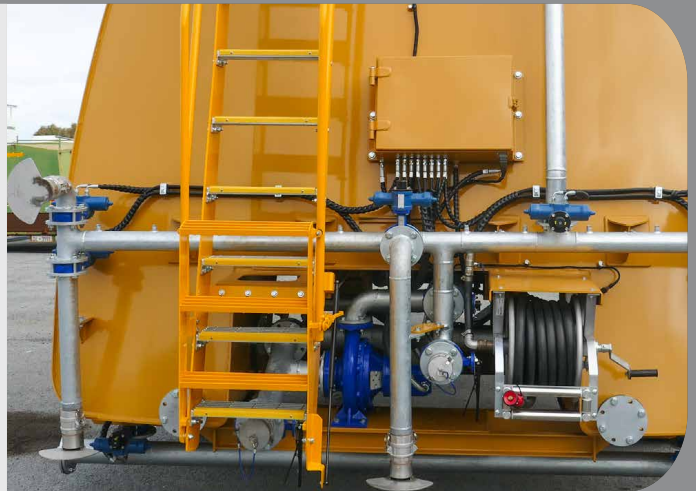

CAB CONTROLS

All our water carts include a conveniently placed in-cab spray and cannon control panel, providing total operating control from the comfort of the cabin.



SERVICE ACCESS

Each unit is built with easily accessible tank lids. Our optional user-friendly access stairs and railings are designed to AS 1657-1992, and provide safe and efficient access to tank lids from the top of the module.



MINE-SPEC

Shermac water carts are fitted with everything needed to comply with mine site compliance. This includes:

- Hand railing access ladders and self-closing gates to AS1657-2013 standards
- High visibility tape around perimeter of tank
- High visibility asset numbers on front, rear, left and right of tank
- High and low level taillights
- Any other mine specifications required



LOW CENTRE OF GRAVITY

Shermac's tanks are designed to keep the centre of gravity as low as possible. By following the slope of the chassis and the curved sides means the top of the tank is narrower than the bottom, helping to keep the weight as low as possible. We also design the tanks to correctly load the axles of the carrier when full.

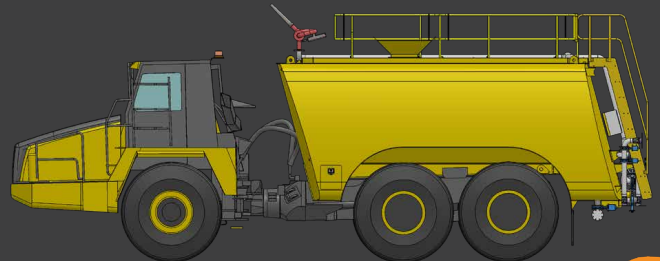

Contact us to discuss
YOUR unique requirements!

1300 799 943
sales@shermac.com.au
www.shermac.com.au

UNIQUE INTERNAL CORROSION PROTECTION METHOD

The most important process in building a water cart is ensuring the internal coating is properly applied, and this demands meticulous preparation.

All internal profile cut edges are ground and all surfaces are grit blasted to class 2.5 and inspected before coating to ensure there are no lapped welds or welding spatter. All internal edges and seams are brushed with an epoxy tank liner and the tank is internally coated with two coats of tank liner.

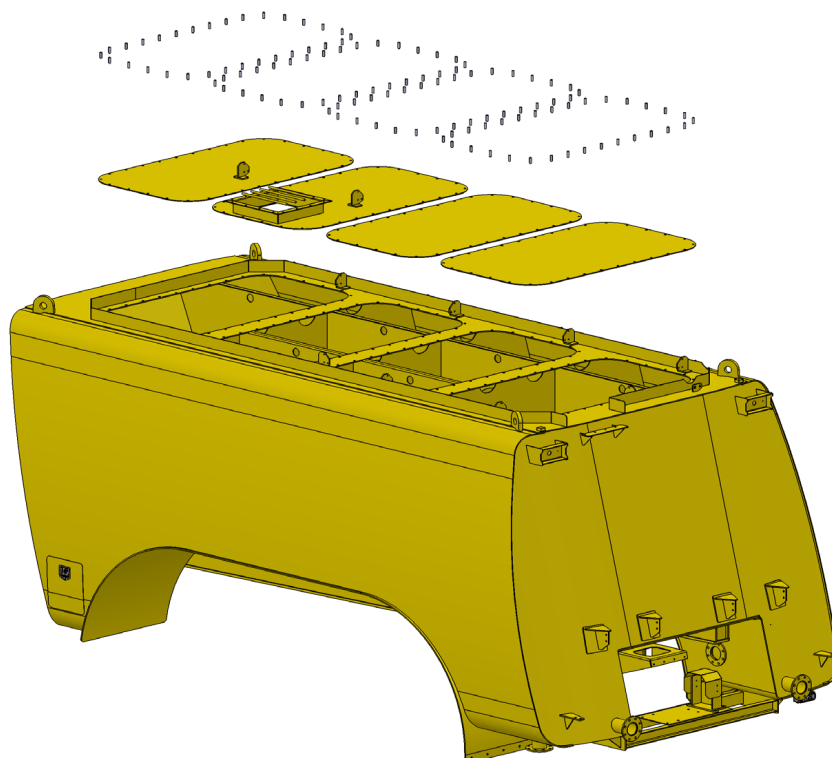

THE SHERMAC WATER CART RANGE

ROADSERVE 1000 SERIES

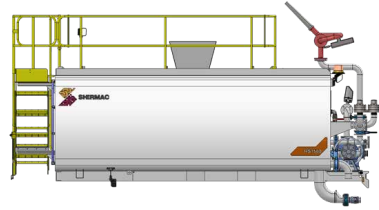
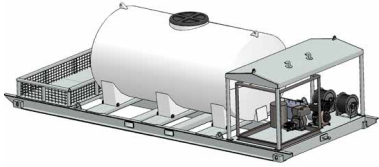

ROADSERVE 1500 SERIES



ROADSERVE 2000 SERIES

ROADSERVE 3000 SERIES



ROADSERVE 4000 SERIES



ROADSERVE 5000 SERIES



Contact us to discuss
YOUR unique requirements!



SHERMAC
Engineered Equipment
Transitions

"We only work with suppliers that genuinely share our worldview and they need to stand behind their product. We like to work with Shermac. We have an alignment of values and a very similar ethos to Shermac. They are a successful business, a great company to work with and, simply, nice people"

Supporting WA companies and their families is a priority for KEE Group and time and time again Shermac raise the bar on market leading engineering and good old fashioned customer service. We sincerely thank our friends at Shermac for your relentless pursuit first class engineering and the magnificent moxy water cart fabrications."

- Kee Group Co-Founder, Damon Spiers



Contact us to discuss
YOUR unique requirements!

1300 799 943
sales@shermac.com.au
www.shermac.com.au



SHERMAC
Engineered Equipment
Transitions

SHERMAC WORK WITH OUR CLIENTS TO:

INCREASE their productivity
DECREASE their machinery downtime
SAVE on their ongoing operating costs
MINIMISE their lifetime cost of ownership
INCREASE their operational safety
INCREASE their bottom line

“The end product was exactly how we hoped it would be delivered. Sales and Production were very easy to deal with, listening to what we required and delivered the product on time, as per quote and built to a quality standard we expected”

“The truck is going exceptionally well. Shermac certainly can take the credit for a great water tank design and quality engineering. The sprays have so much more coverage that we are covering what was a 12-hour shift two hour early!”

“Shermac were easy to deal with and supplied a high-quality service truck body. The fitment to the truck was done quickly and without fuss. I would highly recommend Shermac to anyone”

“Shermac were professional and knowledgeable throughout the whole quote, design and build process. They were fully accountable for the build and delivered it on time, to budget and with great quality”

“Great company to deal with, very professional in all aspects of the contract, superb quality and workmanship, would highly recommend them”



SHERMAC

Engineered Equipment
Transitions

Shermac Australia Pty Ltd

ABN 54 622 839 810
15 Deacon Street
Dalwallinu 6609
Western Australia

PO Box 414
Dalwallinu 6609
Western Australia

Freecall 1300 799 943
Telephone 08 9661 2330
Facsimile 08 9661 2300

sales@shermac.com.au
www.shermac.com.au

Driving Performance Capacity

